

INNOVATIVE SOLUTIONS
FOR VENTILATORS



MFA0300

Blower for High Performance & Reliability

AIRFAN blower architecture with **patented motor cooling system** and unique **soundproof housing**.

The **MFA0300** is perfectly suited for implementation in ventilators dedicated to Acute, Sub-Acute and Home Care.

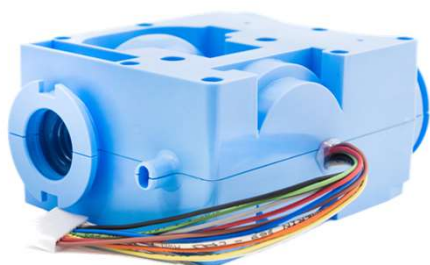

PERFORMANCES

ΔP max @24V		90 hPa	fully closed
Q max @24V		320 l/mn	fully opened
Typical w/p @30 l/mn		P = 12.5 (W)	@30 hPa
		P = 22.8 (W)	@60 hPa
LifeTime (L10)		> 40 000 hours*	
Type		Casing integration	

* LifeTime expectancy based on standard operating conditions

 Dynamic transient time*	< 101 ms	@3A max
	< 78 ms	@6A max
	< 68 ms	@10A max
<i>* from 5 to 60 hPa @30 l/mn</i>		
 Noise Level*	< 29 dBa	@10 hPa
	< 40 dBa	@50 hPa
	< 46 dBa	@100 hPa
<i>* with Blower inlet @1m</i>		

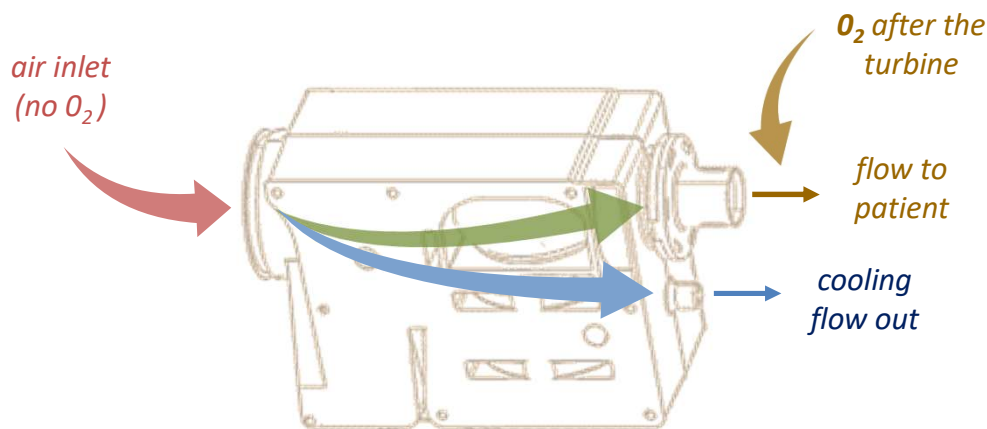

TECHNICAL DATA

Voltage supply	24 VDC (nom) 28 VDC (max)
Motor type	Brushless with Hall-effect sensors
Dimensions (casing)	130 x 100 x 61 mm (5.3 x 3.9 x 2.4 in)
Weight	0.44 kg (~ 1.00 Lb)
Integration	works in any position/orientation
Temperature	-20 to +50°C ambient
Humidity	0 to 95% RH non condensing
Atmospheric pressure	700 to 1100 hPa
Oxygen compatibility	no

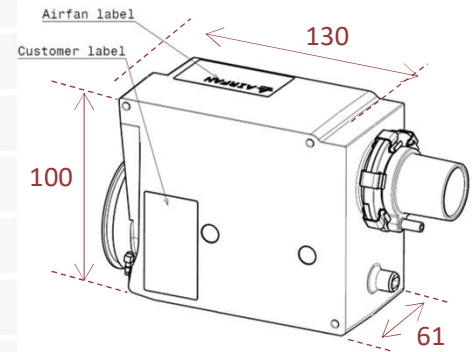

COMPRESSOR MAP

Static ΔP vs Airflow at Constant PWM and Motor Voltage

PWM = Pulse Width Modulation

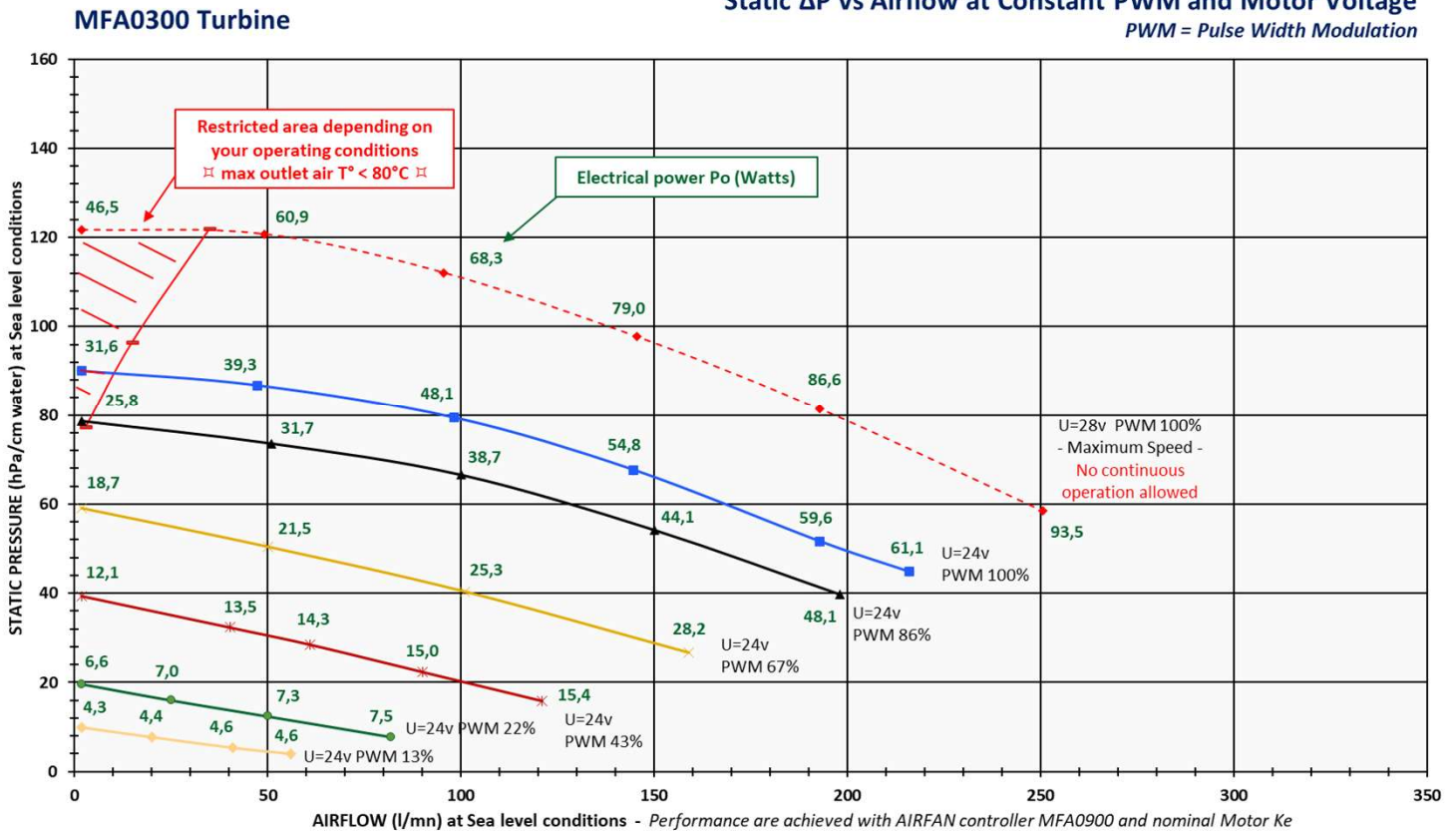

CUSTOMISATION

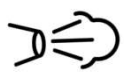

Outlet port

- Outlet port male or female connector (22Ø ISO5356-1) or additional auxiliary ports



- Low Leakage sealing as per ISO80601



- O-ring for air inlet



- Custom label

- Wire Length 150 or custom



CUSTOMISE TO YOUR SPECIFICATIONS

