

INNOVATIVE SOLUTIONS  
FOR VENTILATORS



## MFA0500

## Blower for Blended or 100% Oxygen

Specific blower architecture with **patented motor cooling system completely independent** from the air inlet flow.

The **MFA0500** guarantees a **fully homogeneous Air-Oxygen blend** with complete patient safety in the case of an increase in temperature.

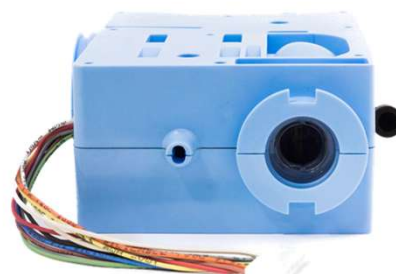

### PERFORMANCES

<b>ΔP max @24V</b>		<b>110 hPa</b>	<b>static pressure</b>	 <b>Dynamic transient time*</b>	<b>&lt; 113 ms</b>	<b>@3A max</b>
<b>Q max @24V</b>		<b>380 l/mn</b>	<b>freeflow</b>		<b>&lt; 85 ms</b>	<b>@6A max</b>
<b>Typical w/p @30 l/mn</b>		<b>P = 12.5 (W) @30 hPa</b>			<b>&lt; 68 ms</b>	<b>@10A max</b>
		<b>P = 22.1 (W) @60 hPa</b>		* from 5 to 60 hPa @30 l/mn		
<b>LifeTime (L10)</b>		<b>&gt; 40 000 hours*</b>		 <b>Noise Level*</b>	<b>&lt; 29 dBa</b>	<b>@10 hPa</b>
<b>Type</b>		<b>Casing integration</b>			<b>&lt; 40 dBa</b>	<b>@50 hPa</b>
					<b>&lt; 46 dBa</b>	<b>@100 hPa</b>

\* LifeTime expectancy based on standard operating conditions

\* with Blower inlet @1m

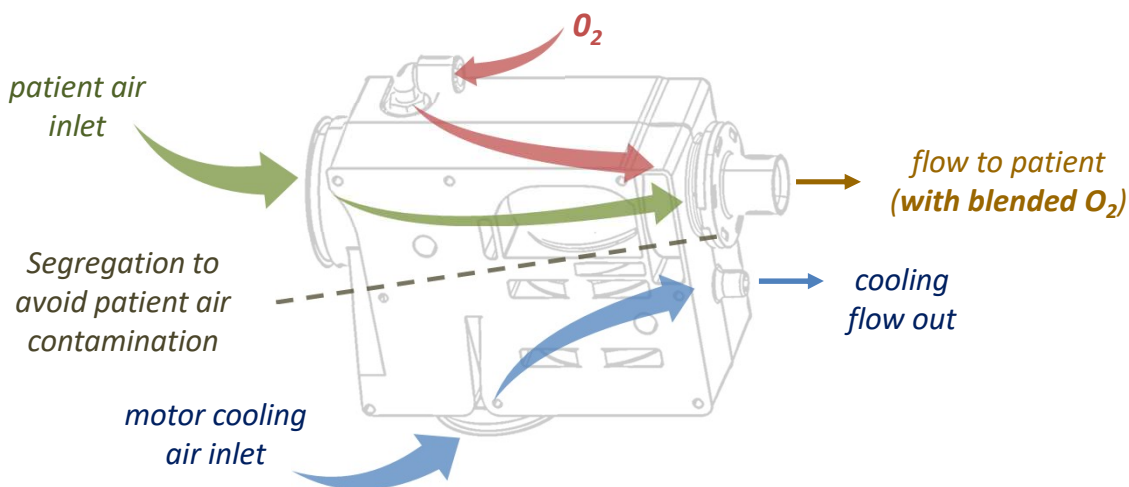

## TECHNICAL DATA

Voltage supply	24 VDC (nom)   28 VDC (max)
Motor type	Brushless with Hall-effect sensors
Dimensions (casing)	130 x 100 x 61 mm (5.3 x 3.9 x 2.4 in)
Weight	0.45 kg (~ 1.00 Lb)
Integration	works in any position/orientation
Temperature	-20 to +50°C ambient
Humidity	0 to 95% RH non condensing
Atmospheric pressure	700 to 1100 hPa
Oxygen compatibility	100% O2 compatible

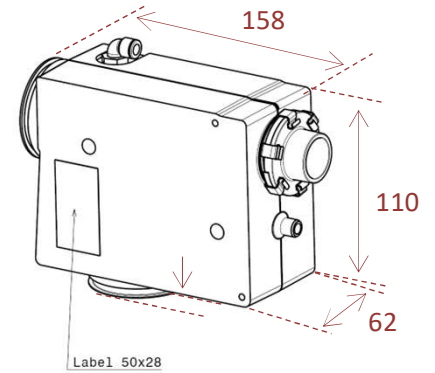

## COMPRESSOR MAP

Static  $\Delta P$  vs Airflow at Constant PWM and Motor Voltage  
PWM = Pulse Width Modulation

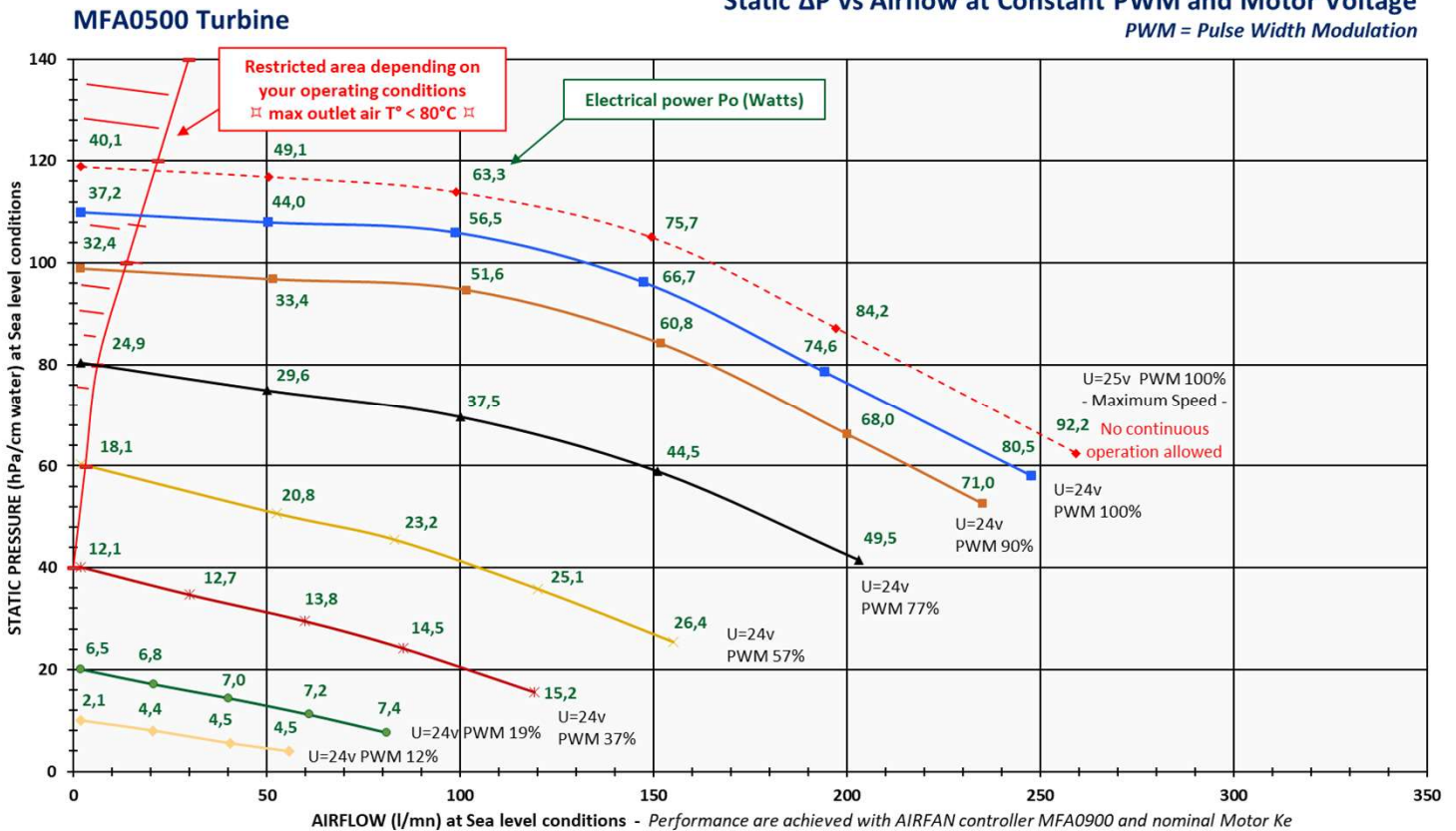

## CUSTOMISATION

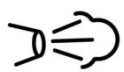

Outlet port

- Outlet port male or female connector (22Ø ISO5356-1) or additional auxiliary ports



- Low Leakage sealing as per ISO80601



- O-ring for air inlet



- Custom label



- Inlet filter for motor cooling



- Wire Length 150 or custom



CUSTOMISE TO YOUR SPECIFICATIONS

