

MFA0020

Blower designed for specific integration

Specific blower architecture with **patented motor cooling system**.

The **MFA0020** is designed for implementation in ventilators dedicated to **Home Care, BiPAP and CPAP** with good **acceleration** and a **long operational life**.



PERFORMANCES

ΔP max @24V		80 hPa	fully closed
Q max @24V		300 l/mn	fully opened
Typical w/p @30 l/mn		P = 10.0 (W)	@30 hPa
		P = 19.0 (W)	@60 hPa
LifeTime (L10)		> 35 000 hours*	
Type		Naked turbine	

 Noise Level*	< 50 dBa	@10 hPa
	< 61 dBa	@30 hPa
	< 66 dBa	@60 hPa

* with Blower inlet @1m

* LifeTime expectancy based on standard operating conditions

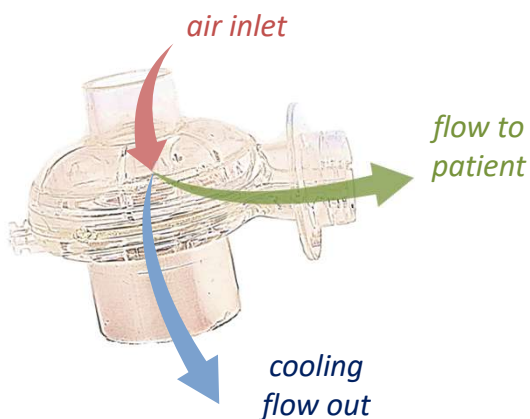

TECHNICAL DATA

Voltage supply	24 VDC (nom) 28 VDC (max)
Motor type	Brushless without Hall-effect sensors
Dimensions (casing)	Ø55 x 55 mm (Ø2.2 x 2.2 in)
Weight	0.08 kg (~ 0.17 Lb)
Integration	works in any position/orientation
Temperature	-20 to +50°C ambient
Humidity	0 to 95% RH non condensing
Atmospheric pressure	700 to 1100 hPa
Oxygen compatibility	No – (Optional Yes with MFA0021)

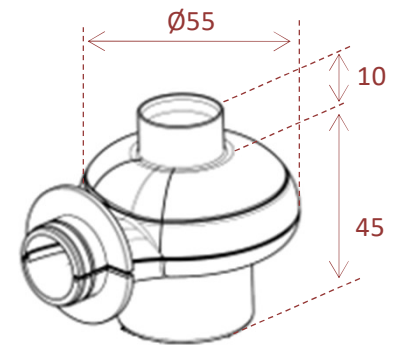

COMPRESSOR MAP

MFA0020 Turbine

Static ΔP vs Airflow at Constant PWM and 24Vdc

PWM = Pulse Width Modulation

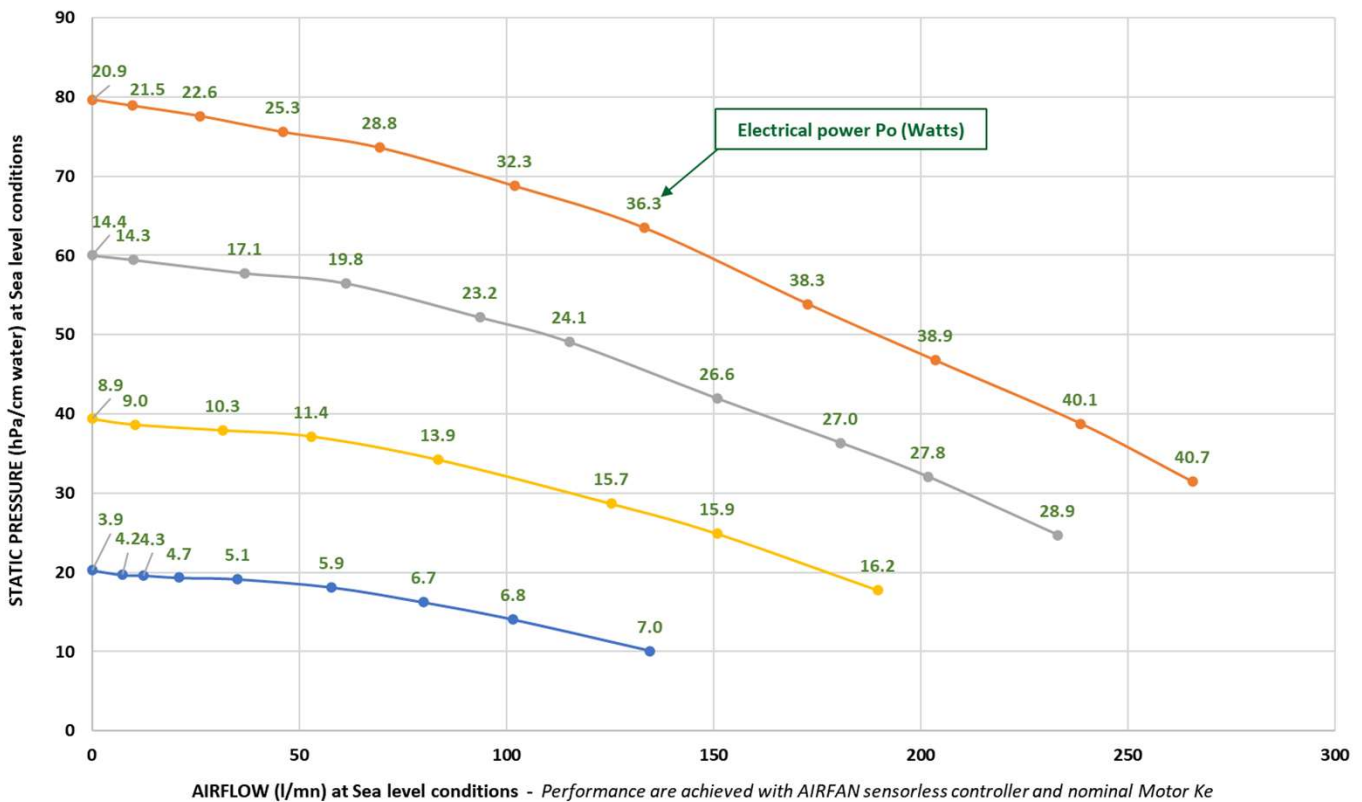

CUSTOMISATION



- with or without inlet tube

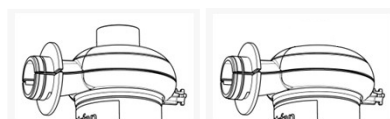

ASK FOR YOUR CUSTOMISATION



- Optional wiring harness



- Oxygen compatibility with MFA0021 (Lifetime: 25 000 hours)

